

# A Series Internal Combustion Forklift Trucks

**CPCD50-70AS4**  
**CPCD85-100AW2**  
5000-10000 kg Capacity

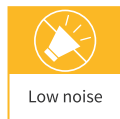

Why choose between price and quality **WHEN YOU CAN HAVE BOTH!**

## HIGHLIGHTS

- ▶ Full LED lighting system and eco-friendly materials throughout the vehicle.
- ▶ Spacious and comfortable cab.
- ▶ Linkage-type shift mechanism.
- ▶ High-position exhaust system.
- ▶ 15% increased forward visibility.
- ▶ 20% faster lifting speed with high-efficiency lifting system.
- ▶ Maximum forward tilt angle of 10°.
- ▶ 10% reduced vehicle vibration through damping design.
- ▶ 10% lower fuel consumption.
- ▶ 2dB noise reduction.
- ▶ Travel speed increased by 15%.
- ▶ Integrated radiator reduces coolant temperature by 10%, oil temperature by 20%.
- ▶ Reinforced steering axle system extends service life by 20%.
- ▶ High-pressure common rail fuel system reduces failure rate by 80%.



## CPCD50-70AS4 CPCD85-100AW2

5000-10000 kg. Capacity

The A Series 5–10t IC Forklifts are heavy-duty counterbalanced trucks independently developed by Noblift, featuring advanced technology, modern family-style design, a 6-cylinder fuel-efficient engine, enhanced ergonomics, reinforced mast structure, and a highly reliable cooling system. This makes them the preferred choice for demanding applications.

## A Series Internal Combustion Forklift Trucks

- The vehicle exterior follows the A Series family design, adopting a standard wheelbase, small turning radius, and flexible operation.
- Standard configuration adopts a 6-cylinder National IV engine with stronger power, lower noise, good response at low to medium speeds, and smooth start-up, extending overhaul intervals under heavy-duty conditions.
- The standard 10t truck has a self-weight of 13.7t, meeting the needs of stone, steel, timber, ports, and rental markets without additional options or modifications.
- Heavy-duty transmission for port applications, paired with a reinforced hub reduction drive axle to support intensive operations. Steering axle kingpin bearings adopt tapered roller bearings for the first time in the industry, extending steering axle life.
- Reinforced design of frame and mast structures meets heavy-duty operating requirements.
- Reinforced mast for port applications, featuring a full-width load backrest aligned with the truck frame, eight main rollers, six side rollers, and a heavy-duty fork positioner cylinder to withstand demanding heavy-duty and unbalanced loads.
- Optimized cooling duct in counterweight with widened plate-fin radiator significantly improves vehicle thermal balance, ensuring reliable engine and transmission operation.
- Standard hydraulic oil cooler and return oil filter ensure hydraulic system reliability under continuous heavy-duty operations.
- Floating seat, audio-visual alarm, and color display instrument are all standard.
- Floorboard and side panels removable without tools, engine hood opens 80°, providing convenient and fast maintenance.



# Intelligent, safe, and reliable

### Color Display



Smart LCD display with real-time vehicle status monitoring.

### Wide-View Reinforced Mast



10t model equipped with 8 main and 6 side rollers, optimized for heavy-duty use.

### Independent ECU Box



ECU, fuse box, and preheating relays integrated for easy service.

### Exhaust System



Convenient removal from counterweight side for maintenance.

### Cup Holder & Pen Holder



Stylish cup holder and pen storage.

### Hydraulic Oil Cooler

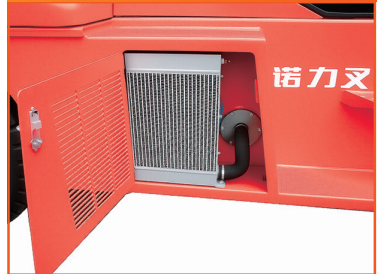

Side-mounted cooler reduces oil temperature.

### Large Hood Opening



80° engine hood opening for easy access.

### Heavy-Tread Tires



Stronger grip and durability.



### Easy Maintenance



Simplified servicing of key components.

### Full LED Lighting



Full LED lighting system.

### Optional A/C Cabin



Air conditioning available for enhanced comfort.

### Reinforced Steering Axle



With tapered roller bearings.

## Structure diagram

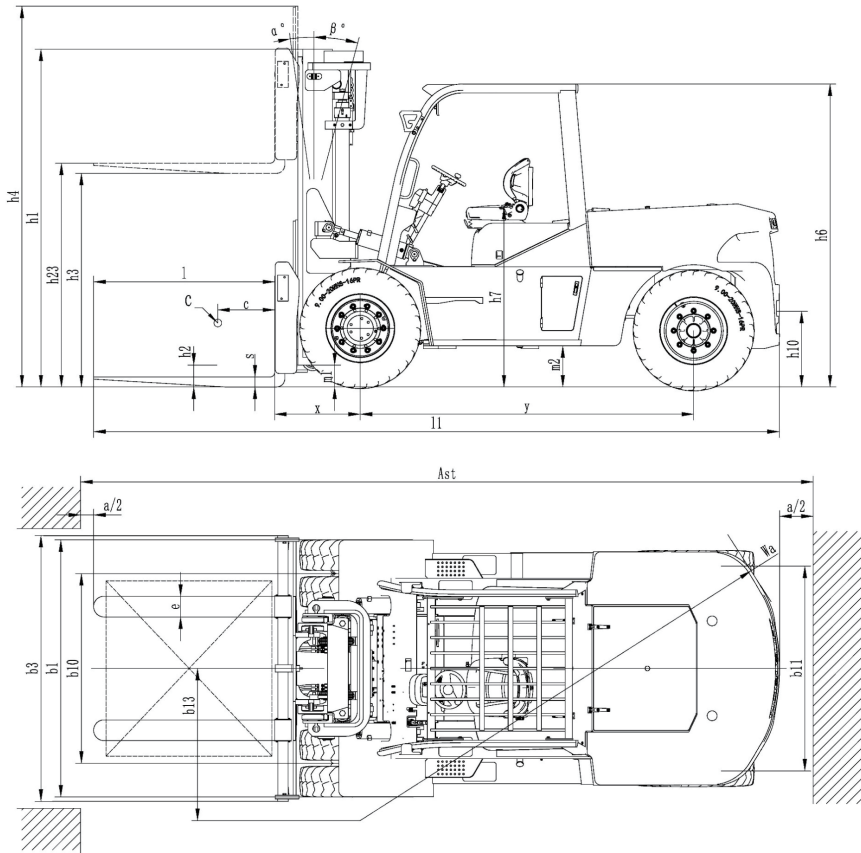

## Load curve graph

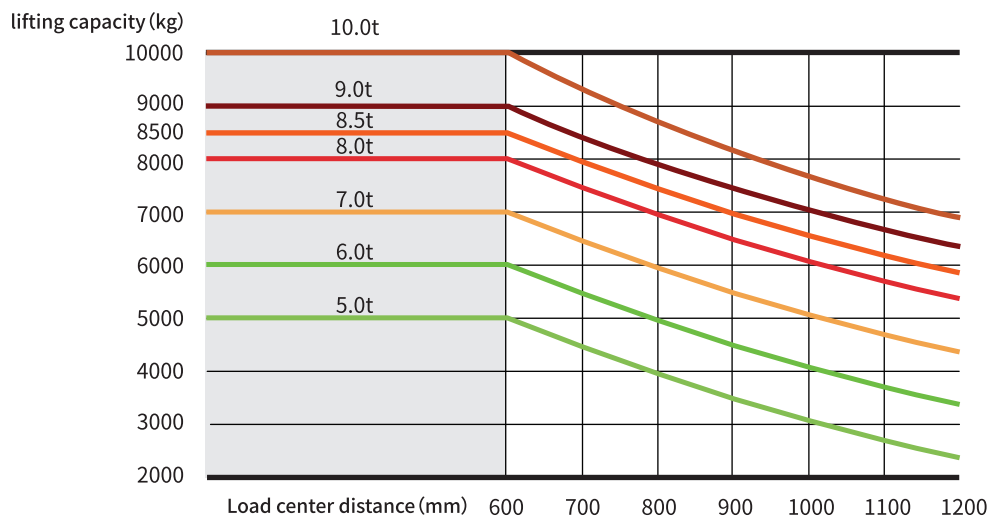

## Engine Configuration Table

Engine Description	Quan Chai S65-130C41 Turbocharged Intercooled High-Pressure Common Rail+ EGR+DOC+DPF	Yu Chai YCA05115-S500 Turbocharged Intercooled High-Pressure Common Rail SCR + DOC + DPF	Yu Chai YCA04130-T480 Turbocharged Intercooled High-Pressure Common Rail SCR + DOC + DPF	Isuzu 6BG1QC-02 Inline Pump	Mitsubishi S6S-T Turbocharged VE Pump
Engine Model	Q3	Y1	Y2	W2	S4
Power Type	Diesel	Diesel	Diesel	Diesel	Diesel
Emission Standard	China IV	Euro V	China IV	China I	Euro IIIa
Power	95.6/2200	85/2200	96/2200	82.4/2000	68/2300
Torque	540/1400-1650	500/1300-1500	530/1300-1600	417/1500	296/1700
Displacement	6.67	4.837	4.58	5.785	4.966
Applicable Capacity	5-10t	5-10t	5-10t	5-10t	5-10t

A Series Internal Combustion Forklift Trucks Mast Parameters Table

No.20251110(V3)

Designation	Mast table	Lift height	Mast height			Free lift						Front overhang			Tilt angle	Load capacity		
			Closed mast height	Extended mast height		Without load backrest			With load backrest							Capacity table(kg) C=600mm without attachment		
				mm	mm	mm	mm			mm			mm			forward/ backward (°)	5t	6t
			mm	5t/6t/7t	5t/6t/7t	5t/6t/7t	5t	6t	7t	5t	6t	7t	5t	6t	7t		kg	kg
Two-stage ZT	A50/60/70/M250	2500	2250	3850	4170	155	160	165	155	160	165	575	580	585	6/12	5000	6000	7000
	A50/60/70/M270	2700	2350	3950	4270	155	160	165	155	160	165	575	580	585	6/12	5000	6000	7000
	A50/60/70/M300	3000	2500	4100	4420	155	160	165	155	160	165	575	580	585	6/12	5000	6000	7000
	A50/60/70/M330	3300	2650	4250	4570	155	160	165	155	160	165	575	580	585	6/12	5000	6000	7000
	A50/60/70/M350	3500	2750	4350	4670	155	160	165	155	160	165	575	580	585	6/12	5000	6000	7000
	A50/60/70/M375	3750	2875	4475	4795	155	160	165	155	160	165	575	580	585	6/12	5000	6000	7000
	A50/60/70/M400	4000	3050	4650	4970	155	160	165	155	160	165	575	580	585	6/12	5000	6000	7000
	A50/60/70/M425	4250	3175	4775	5095	155	160	165	155	160	165	575	580	585	6/12	5000	6000	7000
	A50/60/70/M450	4500	3300	4900	5220	155	160	165	155	160	165	575	580	585	6/12	5000	6000	7000
	A50/60/70/M475	4750	3425	5025	5345	155	160	165	155	160	165	575	580	585	6/6	5000	6000	7000
	A50/60/70/M500	5000	3550	5150	5470	155	160	165	155	160	165	575	580	585	6/6	5000	6000	7000
	A50/60/70/M550	5500	3850	5450	5770	155	160	165	155	160	165	575	580	585	6/6	4700	5700	6600
	A50/60/70/M600	6000	4100	5700	6020	155	160	165	155	160	165	575	580	585	6/6	4400	5400	6300
A50/60/70/M650	6500	4450	6050	6370	155	160	165	155	160	165	575	580	585	6/6	4000	5000	6000	
Two-stage Full Free Lift	A50/60/70/U250	2500	2250	3750	3750	1250			840			575	580	585	6/12	5000	6000	7000
	A50/60/70/U270	2700	2350	3950	3950	1350			940			575	580	585	6/12	5000	6000	7000
	A50/60/70/U300	3000	2500	4250	4250	1500			1090			575	580	585	6/12	5000	6000	7000
	A50/60/70/U330	3300	2650	4550	4550	1650			1240			575	580	585	6/12	5000	6000	7000
	A50/60/70/U350	3500	2750	4750	4750	1750			1340			575	580	585	6/12	5000	6000	7000
	A50/60/70/U375	3750	2875	5000	5000	1875			1465			575	580	585	6/12	5000	6000	7000
	A50/60/70/U400	4000	3050	5250	5250	2050			1590			575	580	585	6/12	5000	6000	7000
	A50/60/70/U425	4250	3175	5500	5500	2175			1715			575	580	585	6/12	5000	6000	7000
	A50/60/70/U450	4500	3300	5750	5750	2300			1840			575	580	585	6/12	5000	6000	7000
	A50/60/70/U475	4750	3425	6000	6000	2425			1965			575	580	585	6/6	5000	6000	7000
	A50/60/70/U500	5000	3550	6250	6250	2550			2090			575	580	585	6/6	4700	5700	6600
	A50/60/70/U550	5500	3850	6750	6750	2850			2340			575	580	585	6/6	4400	5400	6300
A50/60/70/U600	6000	4100	7250	7250	3100			2590			575	580	585	6/6	4000	5000	6000	
Three-stage Full Free Lift	A50/60/70/N360	3600	2325	4850	4850	1230			910			635	640	645	6/12	5000	6000	7000
	A50/60/70/N400	4000	2450	5250	5250	1360			1040			635	640	645	6/12	5000	6000	7000
	A50/60/70/N435	4350	2575	5600	5600	1470			1150			635	640	645	6/12	5000	6000	7000
	A50/60/70/N450	4500	2630	5750	5750	1520			1200			635	640	645	6/6	5000	6000	7000
	A50/60/70/N480	4800	2730	6050	6050	1630			1310			635	640	645	6/6	5000	6000	7000
	A50/60/70/N500	5000	2795	6250	6250	1700			1380			635	640	645	6/6	5000	6000	7000
	A50/60/70/N550	5500	2960	6750	6750	1890			1570			635	640	645	6/6	5000	6000	7000
	A50/60/70/N600	6000	3125	7250	7250	2030			1710			635	640	645	6/6	4700	5700	6600
	A50/60/70/N650	6500	3395	7750	7750	2295			1975			635	640	645	6/6	4400	5400	6300
	A50/60/70/N700	7000	3500	8250	8250	2405			2085			635	640	645	6/6	4000	5000	6000

A Series Internal Combustion Forklift Trucks Performance Parameters Table

No.20251110(V3)

Identification	1.1	Manufacture(abbreviation)		NOBLELIFT	NOBLELIFT	NOBLELIFT	
	1.2	Manufacturer's type designation		CPCD50L-AS4	CPCD60-AS4	CPCD70-AS4	
	1.3	Drive:electric(battery or mains),diesel,petrol gas>manual)		Diesel	Diesel	Diesel	
	1.4	Type of operation(hand,pedestrian,standing,seated,order-picker)		Seated	Seated	Seated	
	1.5	Load capacity/rated load	Q(kg)	5000	6000	7000	
	1.6	Load centre distance	C(mm)	600	600	600	
	1.8	Load distance,centre of drive axle to fork	x(mm)	575	580	585	
	1.9	wheelbase	y(mm)	2400	2400	2400	
Weights	2.1	Service weight incl	kg	8500	9050	9700	
	2.2	Axle loading ,laden front/rear	kg	12000/1500	13450/1600	14900/1800	
	2.3	Axle loading,unladen front/rear	kg	4050/4450	4250/4800	4350/5350	
Wheels、Chassis	3.1	Type:solid rubber,superelastic,pneumatic,polyurethane		Pneumatic tire	Pneumatic tire	Pneumatic tire	
	3.2	Tyres size,front		8.25-15-14PR	8.25-15-14PR	8.25-15-14PR	
	3.3	Tyres size,rear		8.25-15-14PR	8.25-15-14PR	8.25-15-14PR	
	3.5	Wheels,number front/rear(×=driven wheels)		4X/2	4X/2	4X/2	
	3.6	Track width,front	b10(mm)	1470	1470	1470	
	3.7	Track width,rear	b11(mm)	1720	1720	1720	
Basic Dimensions	4.1	Mast/fork carriage tilt forward/backward	$\alpha/\beta(^{\circ})$	6/12	6/12	6/12	
	4.2	Lowered mast height	h1(mm)	2500	2500	2500	
	4.3	Free lift	h2(mm)	155	160	165	
	4.4	Lift height	h3(mm)	3000	3000	3000	
	4.4a	Lift height (Including cargo fork)	h23(mm)	3055	3060	3065	
	4.5	Extended mast height	h4(mm)	4400	4400	4400	
	4.7	Overhead load guardheight	h6(mm)	2460	2460	2460	
	4.8	Seat height/standing height	h7(mm)	1430	1430	1430	
	4.12	Coupling heigh	h10(mm)	390	390	390	
	4.19	Overall length (Including cargo fork)	l1(mm)	5190	5190	5190	
	4.20	Overall length	l2(mm)	3670	3670	3670	
	4.21	Overall width (Frame/tires)	b1(mm)	1995	1995	1995	
	4.22	Fork dimensions	s/e/l(mm)	55×150×1520	60×150×1520	65×150×1520	
	4.23	Fork mounting grade		4A	4A	4A	
	4.24	Width of fork rack	b3(mm)	1845	1845	1845	
	4.31	Ground clearance ,laden,under mast	m1(mm)	200	200	200	
	4.32	Ground clearance,centre of wheelbase	m2(mm)	240	240	240	
	4.34.1	Aisle width for pallets 1000×1200 crossways	Ast(mm)	5350	5350	5350	
4.34.2	Aisle width for pallets 800×1200 lengthways	Ast(mm)	5550	5550	5550		
4.35	Turning radius	Wa(mm)	3350	3350	3350		
4.36	Inside turning radius	b13(mm)	250	250	250		
Performance Data	5.1	Travel speed,laden/unladen	hydrodynamic drive	km/h	26/28	26/28	25/28
	5.2	Lift speed,laden/unladen	Two stage gantry	mm/s	430/440	420/440	410/440
	5.3	Lowering speed,laden/unladen	Two stage gantry	mm/s	400/380	400/380	400/380
	5.6	Max.Drawbar pull ,laden/unladen	hydrodynamic drive	kN	82/45	82/45	82/45
	5.7	Max.Gradient performance,laden/unladen S2	hydrodynamic drive	%	25/20	25/20	25/20
	5.10	Service brake			Hydraulic	Hydraulic	Hydraulic
	5.11	Parking braking			Mechanical	Mechanical	Mechanical
Engine	7.1	Engine builder		Mitsubishi S6S-T (Euro IIIA)	Mitsubishi S6S-T (Euro IIIA)	Mitsubishi S6S-T (Euro IIIA)	
	7.2	Engine power rating ISO1585	kw	68	68	68	
	7.3	Rated speed	rpm	2300	2300	2300	
	7.4	Number of cylinders/displacement	cm3	6/4966	6/4966	6/4966	
	7.5a	Maximum torque	N.m/rpm	296/1700	296/1700	296/1700	
	7.9	Nominal voltage	V	24	24	24	
	7.10	Battery capacity	V/Ah	24/90	24/90	24/90	
Transmission	8.1	Transmission type		Hydrodynamic	Hydrodynamic	Hydrodynamic	
	8.2	Gear forward/backward		2/2	2/2	2/2	
	8.3	Shifting mode		Hydraulic	Hydraulic	Hydraulic	
Other Details	10.1	Operating pressure for attachments	Mpa	21	21	21	
	10.2	Oil volume for attachments	L/min	60	60	60	
	10.4	Fuel tank volume	L	140	140	140	
	10.8	Traction pin specification DIN 15170		45	45	45	

# A Series Internal Combustion Forklift Trucks Mast Parameters Table

No.20251110(V3)

Designation	Mast table	Lift height	Mast height						Free lift				Front overhang	Tilt angle	Load capacity		
			Closed mast height		Extended mast height				Without load backrest		With load backrest				Capacity table(kg) C=600mm without attachment		
			mm		mm		mm		mm		mm		Double tire				
			mm	8.5t/9t	10t	8.5t/9t	10t	8.5t/9t	10t	8.5t/9t	10t	8.5t/9t	10t	mm	forward/backward	(°)	8.5t
															kg	kg	kg
Two-stage ZT	A85/90/100/M250	2500	2450	2600	3750	3750	3750	3750	190	200	700	710	6/12	8500	9000	10000	
	A85/90/100/M270	2700	2550	2700	3950	3950	3950	3950	190	200	700	710	6/12	8500	9000	10000	
	A85/90/100/M300	3000	2700	2850	4250	4250	4250	4250	190	200	700	710	6/12	8500	9000	10000	
	A85/90/100/M330	3300	2850	3000	4550	4550	4550	4550	190	200	700	710	6/12	8500	9000	10000	
	A85/90/100/M350	3500	2950	3100	4750	4750	4750	4750	190	200	700	710	6/12	8500	9000	10000	
	A85/90/100/M375	3750	3075	3225	5000	5000	5000	5000	190	200	700	710	6/12	8500	9000	10000	
	A85/90/100/M400	4000	3250	3400	5250	5250	5250	5250	190	200	700	710	6/12	8500	9000	10000	
	A85/90/100/M425	4250	3375	3525	5500	5500	5500	5500	190	200	700	710	6/12	8000	9000	10000	
	A85/90/100/M450	4500	3500	3650	5750	5750	5750	5750	190	200	700	710	6/12	7500	8500	10000	
	A85/90/100/M475	4750	3625	3775	6000	6000	6000	6000	190	200	700	710	6/6	7000	8000	9500	
	A85/90/100/M500	5000	3750	3900	6250	6250	6250	6250	190	200	700	710	6/6	6500	7800	9000	
	A85/90/100/M550	5500	4050	4200	6750	6750	6750	6750	190	200	700	710	6/6	6000	7500	8500	
	A85/90/100/M600	6000	4300	4450	7250	7250	7250	7250	190	200	700	710	6/6	5500	7300	8000	
A85/90/100/M650	6500	4650	4700	7750	7750	7750	7750	190	200	700	710	6/6	5000	6800	7500		
Two-stage Full Free Lift	A85/90/100/U250	2500	2450	2600	3750	3750	3750	3750	1250	1215	700	710	6/12	8500	9000	10000	
	A85/90/100/U270	2700	2550	2700	3950	3950	3950	3950	1350	1315	700	710	6/12	8500	9000	10000	
	A85/90/100/U300	3000	2700	2850	4250	4250	4250	4250	1500	1465	700	710	6/12	8500	9000	10000	
	A85/90/100/U330	3300	2850	3000	4550	4550	4550	4550	1650	1615	700	710	6/12	8500	9000	10000	
	A85/90/100/U350	3500	2950	3100	4750	4750	4750	4750	1750	1715	700	710	6/12	8500	9000	10000	
	A85/90/100/U375	3750	3075	3225	5000	5000	5000	5000	1875	1840	700	710	6/12	8500	9000	10000	
	A85/90/100/U400	4000	3250	3400	5250	5250	5250	5250	2050	2015	700	710	6/12	8500	9000	10000	
	A85/90/100/U425	4250	3375	3525	5500	5500	5500	5500	2175	2140	700	710	6/12	8000	9000	10000	
	A85/90/100/U450	4500	3500	3650	5750	5750	5750	5750	2300	2265	700	710	6/12	7500	8500	10000	
	A85/90/100/U475	4750	3625	3775	6000	6000	6000	6000	2425	2390	700	710	6/6	7000	8000	9500	
	A85/90/100/U500	5000	3750	3900	6250	6250	6250	6250	2550	2515	700	710	6/6	6500	7800	9000	
	A85/90/100/U550	5500	4050	4200	6750	6750	6750	6750	2850	2815	700	710	6/6	6000	7500	8500	
A85/90/100/U600	6000	4300	4450	7250	7250	7250	7250	3100	3065	700	710	6/6	5500	7300	8000		
Three-stage Full Free Lift	A85/90/100/N360	3600	2450	2500	4850	4850	4850	4850	1200	1150	740	750	6/12	6800	8000	9500	
	A85/90/100/N400	4000	2575	2680	5250	5250	5250	5250	1330	1280	740	750	6/12	6800	8000	9500	
	A85/90/100/N435	4350	2700	2800	5600	5600	5600	5600	1450	1400	740	750	6/12	6800	8000	9500	
	A85/90/100/N450	4500	2750	2850	5750	5750	5750	5750	1500	1450	740	750	6/6	6800	8000	9500	
	A85/90/100/N480	4800	2850	2950	6050	6050	6050	6050	1600	1550	740	750	6/6	6800	8000	9500	
	A85/90/100/N500	5000	2950	3015	6250	6250	6250	6250	1700	1615	740	750	6/6	6300	8000	9500	
	A85/90/100/N550	5500	3075	3205	6750	6750	6750	6750	1830	1805	740	750	6/6	5900	7500	8500	
	A85/90/100/N600	6000	3375	3405	7250	7250	7250	7250	2130	2005	740	750	6/6	5300	7000	8000	
	A85/90/100/N650	6500	3600	3480	7750	7750	7750	7750	2350	2170	740	750	6/6	4800	6500	7500	
	A85/90/100/N700	7000	3750	3835	8250	8250	8250	8250	2500	2435	740	750	6/6	4300	5600	7000	

● Integral Side Shifter (Optional) – Reduces weight by ~200kg.

A Series Internal Combustion Forklift Trucks Performance Parameters Table

No.20251110(V3)

Identification	1.1	Manufacture(abbreviation)		NOBLELIFT	NOBLELIFT	NOBLELIFT
	1.2	Manufacturer's type designation		CPCD85-AW2	CPCD90-AW2	CPCD100-AW2
	1.3	Drive:electric(battery or mains),diesel,petrol gas>manual)		Diesel	Diesel	Diesel
	1.4	Type of operation(hand,pedestrian,standing,seated,order-picker)		Seated	Seated	Seated
	1.5	Load capacity/rated load	Q(kg)	8500	9000	9000
	1.6	Load centre distance	C(mm)	600	600	600
	1.8	Load distance,centre of drive axle to fork	x(mm)	700	700	710
	1.9	wheelbase	y(mm)	2600	2600	2800
Weights	2.1	Service weight incl	kg	12300	12700	13600
	2.2	Axle loading ,laden front/rear	kg	18750/2050	19550/2150	21150/2450
	2.3	Axle loading,unladen front/rear	kg	6300/6000	6300/6400	6500/7100
Wheels、Chassis	3.1	Type:solid rubber,superelastic,pneumatic,polyurethane		Pneumatic tire	Pneumatic tire	Pneumatic tire
	3.2	Tyres size,front		9.00-20-14PR	9.00-20-14PR	9.00-20-14PR
	3.3	Tyres size,rear		9.00-20-14PR	9.00-20-14PR	9.00-20-14PR
	3.5	Wheels,number front/rear(X=driven wheels)		4X/2	4X/2	4X/2
	3.6	Track width,front	b10(mm)	1600	1600	1600
	3.7	Track width,rear	b11(mm)	1720	1720	1720
Basic Dimensions	4.1	Mast/fork carriage tilt forward/backward	$\alpha/\beta(^{\circ})$	6/12	6/12	6/12
	4.2	Lowered mast height	h1(mm)	2700	2700	2850
	4.3	Free lift	h2(mm)	190	190	200
	4.4	Lift height	h3(mm)	3000	3000	3000
	4.4a	Lift height (Including cargo fork)	h23(mm)	3070	3070	3080
	4.5	Extended mast height	h4(mm)	4250	4250	4400
	4.7	Overhead load guardheight	h6(mm)	2560	2560	2560
	4.8	Seat height/standing height	h7(mm)	1470	1470	1470
	4.12	Coupling heigh	h10(mm)	480	480	480
	4.19	Overall length (Including cargo fork)	l1(mm)	5710	5710	6070
	4.20	Overall length	l2(mm)	4040	4040	4250
	4.21	Overall width (Frame/tires)	b1(mm)	2165/2165	2165/2165	2165/2165
	4.22	Fork dimensions	s/e/l(mm)	70×175×1670	70×175×1670	80×175×1670
	4.23	Fork mounting grade		5A	5A	5A
	4.24	Width of fork rack	b3(mm)	2100	2100	2200
	4.31	Ground clearance ,laden,under mast	m1(mm)	250	250	250
	4.32	Ground clearance,centre of wheelbase	m2(mm)	330	330	330
	4.34.1	Aisle width for pallets 1000×1200 crossways	Ast(mm)	5600	5600	5810
4.34.2	Aisle width for pallets 800×1200 lengthways	Ast(mm)	5800	5800	6010	
4.35	Turning radius	Wa(mm)	3700	3700	3900	
4.36	Inside turning radius	b13(mm)	1100	1100	1100	
Performance Data	5.1	Travel speed,laden/unladen	hydrodynamic drive	km/h	26/28	26/28
	5.2	Lift speed,laden/unladen	Two stage gantry	mm/s	360/390	360/390
	5.3	Lowering speed,laden/unladen	Two stage gantry	mm/s	400/380	400/380
	5.6	Max.Drawbar pull ,laden/unladen	hydrodynamic drive	kN	82/45	82/45
	5.7	Max.Gradient performance,laden/unladen	S2 hydrodynamic drive	%	21/20	21/20
	5.10	Service brake			Hydraulic	Hydraulic
	5.11	Parking braking			Mechanical	Mechanical
Engine	7.1	Engine builder		Isuzu 6BG1QC-02 (Euro I )	Isuzu 6BG1QC-02 (Euro I )	Isuzu 6BG1QC-02 (Euro I )
	7.2	Engine power rating ISO1585	kw	82.4	82.4	82.4
	7.3	Rated speed	rpm	2000	2000	2000
	7.4	Number of cylinders/displacement	cm3	6/5785	6/5785	6/5785
	7.5a	Maximum torque	N.m/rpm	417/1500	417/1500	417/1500
	7.9	Nominal voltage	V	24	24	24
	7.10	Battery capacity	V/Ah	24/90	24/90	24/90
Transmission	8.1	Transmission type		Hydrodynamic	Hydrodynamic	Hydrodynamic
	8.2	Gear forward/backward		2/2	2/2	2/2
	8.3	Shifting mode		Hydraulic	Hydraulic	Hydraulic
Other Details	10.1	Operating pressure for attachments	Mpa	21	21	21
	10.2	Oil volume for attachments	L/min	60	60	60
	10.4	Fuel tank volume	L	140	140	140
	10.8	Traction pin specification DIN 15170		45	45	45

# A GLOBAL LEADER

## NOBLELIFT CHINA

Address: 528 Changzhou Road, Taihu  
Sub-district, Changxing, Zhejiang 313100 China  
Tel: 86-572-6210817 6210311  
Fax: 86-572-6210777 6128612  
Email: info@noblelift.com  
Http: www.noblelift.com www.noblelift.cn

## NOBLELIFT NORTH AMERICA

Address: 2461 S Wolf Road Des Plaines, IL 60018  
Tel: 001-847-595-7100  
Fax: 001-847-595-7200  
Email: sales@nobleliftna.com  
Http: www.nobleliftna.com

## NOBLELIFT SOUTH EAST ASIA

No. 7, Jalan Astaka U8/84A, Seksyen U8, Bukit Jelutong,  
40150 Shah Alam, Selangor Darul Ehsan, Malaysia.  
Tel: +603 7831 8555  
Email: sales@nobleliftsea.com  
https: www.nobleliftsea.com

## NOBLELIFT SOUTH EAST ASIA (Vietnam) CO., LTD.

Address: 3rd floor, No. 107, Street 37, Van Phuc  
Residential Area, Hiep Binh Phuoc Ward, Thu  
Duc City, Ho Chi Minh City, Vietnam  
Tel: 84-902 598 460  
E-mail: marketingvn@nobleliftsea.com  
www.nobleliftsea.com.vn

## NOBLELIFT RUSSIA

ООО «Ноблелифт Рус», 195067, Санкт-Петербург  
пр. Маршала Блюхера, д. 78, литер Б  
Тел.: +7-800-700-28-97  
Email: sales@noblelift.com.ru  
Http: www.noblelift.com.ru

## NOBLELIFT EUROPE

Industriepark 2, 48739 Legden, Germany  
Tel: +49 2566 90902-0  
Email: Mail@Noblelift-Germany.com  
Http: www.Noblelift.com

## NOBLELIFT KOREA CO., LTD.

Address: 715-9 Jubook-ri, Cheoin-gu, Yongin-si,  
Kyunggi-do, Korea  
Tel: 82-031 334 1828  
E-mail: info@noblelift.com  
www.noblelift.com

## NOBLELIFT CANADA INC.

Address: 850, Ellingham Avenue, Pointe-Claire, province  
of Québec, Canada, H9R 3S4  
Tel: 1- 514 697 0117  
E-mail: info@nobleliftca.com  
www.nobleliftcanada.com

## NOBLELIFT INTELLIGENT EQUIPMENT CO., LTD.



Official website



Our Wechat



LinkedIn



facebook



YouTube

